

Syncro GUIDE V3

Fire Alarm System Graphics Software

Installation and Commissioning Manual

Man-1079 Issue 08 November 2013



Index	Page
1.0 Overview	3
1.1 Fitting the hardware	3
1.2 PC Connection.....	4
1.2.1 RS232 to RS485 converter connection.....	4
1.2.2 USB to RS485 (USB2-H-6001-M) converter connection.....	5
1.2.3 Isolated USB to RS485 (USB485-STI4W) converter connection	6
1.3 Software Installation.....	8
2.0 GUIDE Run.....	8
2.1 Running GUIDE	8
2.2GUIDE Settings	12
2.2.1 Application tab options.....	12
2.2.2Behaviour tab.....	13
2.2.3 Graphics/Events tab	15
2.2.4 Audio tab.....	20
2.2.5 Status Panels tab	22
2.2.6 Quiet Message tab.....	22
2.2.7 About tab.....	22
2.3 User Setup	22
2.4 Security Code	24
2.5GUIDE Service	25
2.6 View Maps	25
2.7 View Loop Devices	26
2.8 View Zones.....	26
2.9 Print Current Event	26
2.10 Event Log	26
2.11 Map Windows.....	26
2.12Minimise (to use Microsoft Windows)	27
2.13 Log off Administrator.....	27
2.14 Shutdown GUIDE	27
2.16 Side bar (Event Panel).....	27
3.0 Designer	27
3.1 Allocating zones and map links	28
3.2 Drawing and linking zones	29
3.3 Adding devices to maps.....	30
3.4 Main toolbar	31
4.0 BMPGrabber	32

1.0 Overview

The GUIDE fire alarm system graphics software allows up to 64 Syncro fire alarm control panels to be connected to a PC that can display events in text and/or graphical form in response to events that occur on the fire alarm system.

The GUIDE also allows a user to take control of the fire alarm system via a "virtual" fire alarm control panel fascia presented on the PC display.

The GUIDE records all events on the fire alarm system and allows these events to be filtered and presented for analysis in a variety of ways

To connect a Syncro fire alarm system to a PC running GUIDE software, a dongle device must be installed in one of the control panels and connected to a serial port of the PC.

If the fire alarm system consists of more than one fire control panel, information from other fire control panels is transmitted over the fire alarm network to the panel that is connected to the PC.

Each dongle is protected by a security code, which is allocated by Kentec Electronics Limited and once installed and enabled, will only work on the system on which it was originally installed.

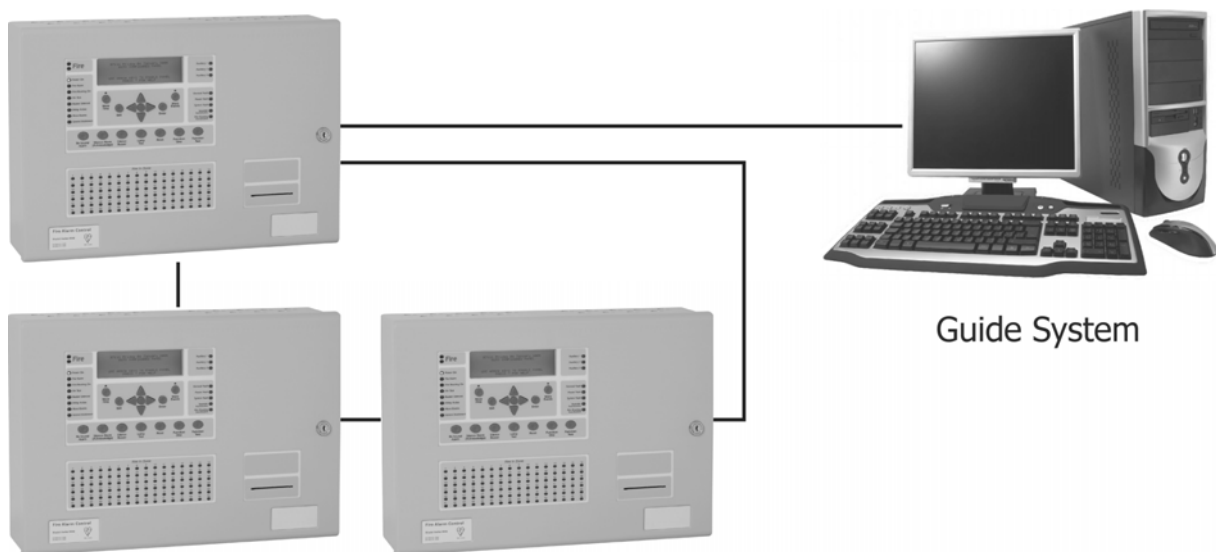

The GUIDE system can be connected to a single fire alarm control panel or a network of control panels by up to 1200 metres of a suitable data cable.

If the GUIDE host computer is connected to a Local Area Network (LAN) then the GUIDE system may be further enhanced by use of GUIDE Repeater displays. Up to 15 GUIDE repeaters can display and control the system information of the Syncro fire network.

1.1 Fitting the hardware

The hardware consists of two parts, the dongle PCB (part number S572), which mounts at the Syncro, Syncro Response or Syncro AS control panel and the RS232/RS485 converter or USB/RS422 converter, which is connected to the computers RS232 or USB serial port.

NOTE: The S572 dongle card cannot be installed in Syncro Focus / Focus + or Syncro View LCD repeaters. The Syncro panel in which the S572 is fitted **must not have a panel printer installed.**

The dongle PCB provides an isolated interface to the fire control panel and allows the data from the GUIDE application to be sent and received at the Syncro panel. The GUIDE system cannot communicate with the fire panel without a dongle that has had its security code enabled.

The dongle PCB is supplied with a ribbon cable (part number SR1012) and clips to connect it to the fire panel display board. Cables to connect to the fire panel Auxiliary 24V supply are fitted to the dongle PCB.

The dongle PCB should be fitted with the power to the control panel turned off.

First plug the dongle PCB onto the standoffs in the fire control panel then connect and route the 10 way ribbon cable to J5 on the front board of the fire panel. Once in place, the ribbon cable should be secured with the self-adhesive clips provided.

Connect the red wire from the S572 dongle PCB to the Aux 24V + terminal in the fire panel.
 Connect the black wire from the S572 dongle PCB to the Aux 24V - terminal in the fire panel.

A 4-CORE data cable suitable for RS485 data communications should be installed from the fire panel to the PC.

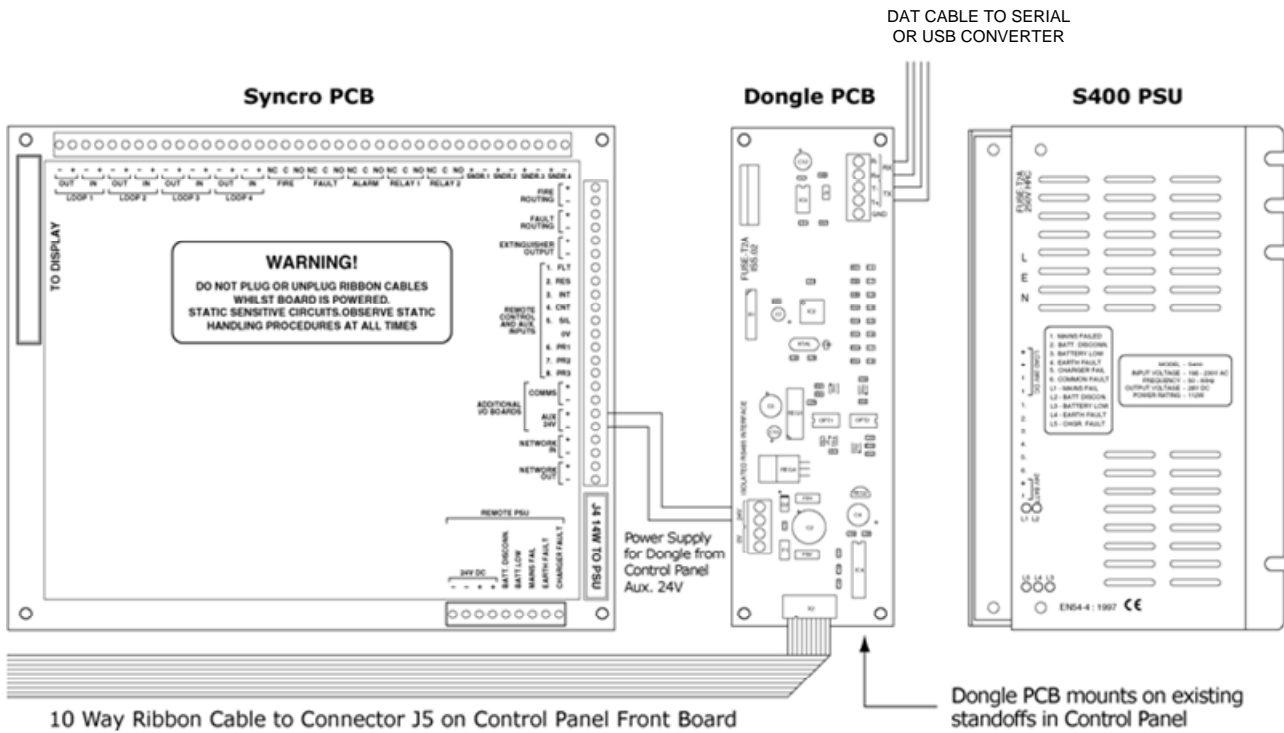

1.2 PC Connection

The GUIDE hardware includes an RS232 to RS485 converter unit or a USB to RS422/485 converter, which enables data to be transmitted over greater distances than the few metres permissible with an RS232 or USB connection. It also provides isolation between the power supply of the PC and that of the fire panel. The RS232 to RS485 plugs into the 9-pin RS232 serial port at the back of the PC or if the USB to RS422 converter is used, this can plug into any available USB port.

The cable used for the data connection must be suitable for RS485 data and must be properly shielded. The recommended cable is Belden 9842. The drain wire of this cable must be terminated to a good earth point within the Syncro panel to ensure maximum immunity to external electromagnetic interference.

The connection to the Syncro panel will not function until the GUIDE software is installed and a valid security code is obtained from Kentec Electronics Limited.

1.2.1 RS232 to RS485 converter connection

When using the RS232 to RS485 converter, connect the data cable from the fire panel as follows:

<u>RS232 /485 Converter Terminal</u>	<u>Panel Dongle PCB Terminal</u>
+ XMT	R+
- XMT	R-
- RCV	T-
+ RCV	T+

Belden 9842 Data cable to fire panel

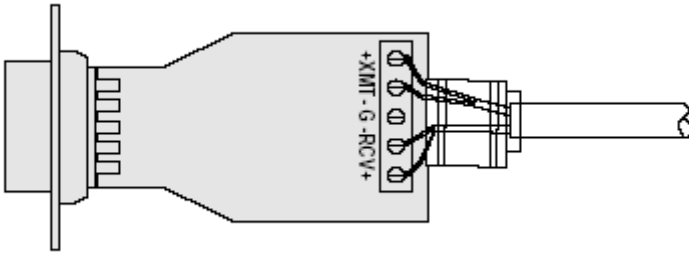

The data cable should be secured to the converter using the cable clamp and routed such that it is not likely to be stressed.

The data converter has two internal PCBs, each with a 4-position DIL switch. It should not be necessary to change these switches from the factory default settings, which are as follows –

MAIN BOARD

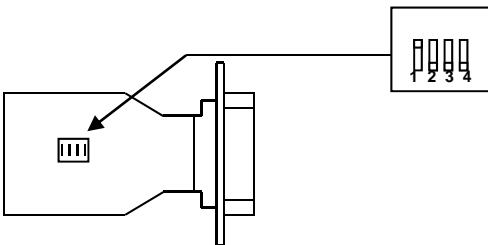

Switch 1 ON
Switch 2,3,4 OFF

DAUGHTER BOARD

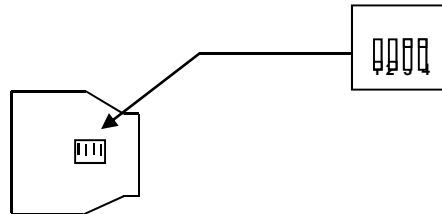

Switch 1,2 OFF
Switch 3,4 ON

The position of the connectors on the rear of PCs differ widely, but there are normally two D type connectors and the RS232/RS485 interface module should be plugged into the 9 pin connector and secured with the fixing screws provided.

Alternatively, if the computer does not have a RS232 serial port available, then a USB to RS232 serial port conversion device may be used. The Kentec U187 part may be used to provide a RS232 data source from the USB port of the computer but in this case it is better to use the USB to RS422 converter detailed below.

1.2.2 USB to RS485 (USB2-H-6001-M) converter connection

When using the USB to RS422 converter, connect the supplied USB cable to the converter and to the PC USB port and connect the data cable from the fire panel as follows:

<u>USB /RS422 Converter Terminal</u>	<u>Panel Dongle PCB Terminal</u>
TXD+	R-
TXD-	R+
RXD+	T-
RXD-	T+

In addition, the CTS+ and RTS+ terminals should be linked together and the CTS- and RTS- terminals linked together, as shown in the diagram below.

NOTE: The Windows Virtual Com Port (VCP) driver for this unit is not supplied with the unit and should be downloaded from the EasySYNC web site - <http://www.ftdichip.com/Drivers/VCP.htm>

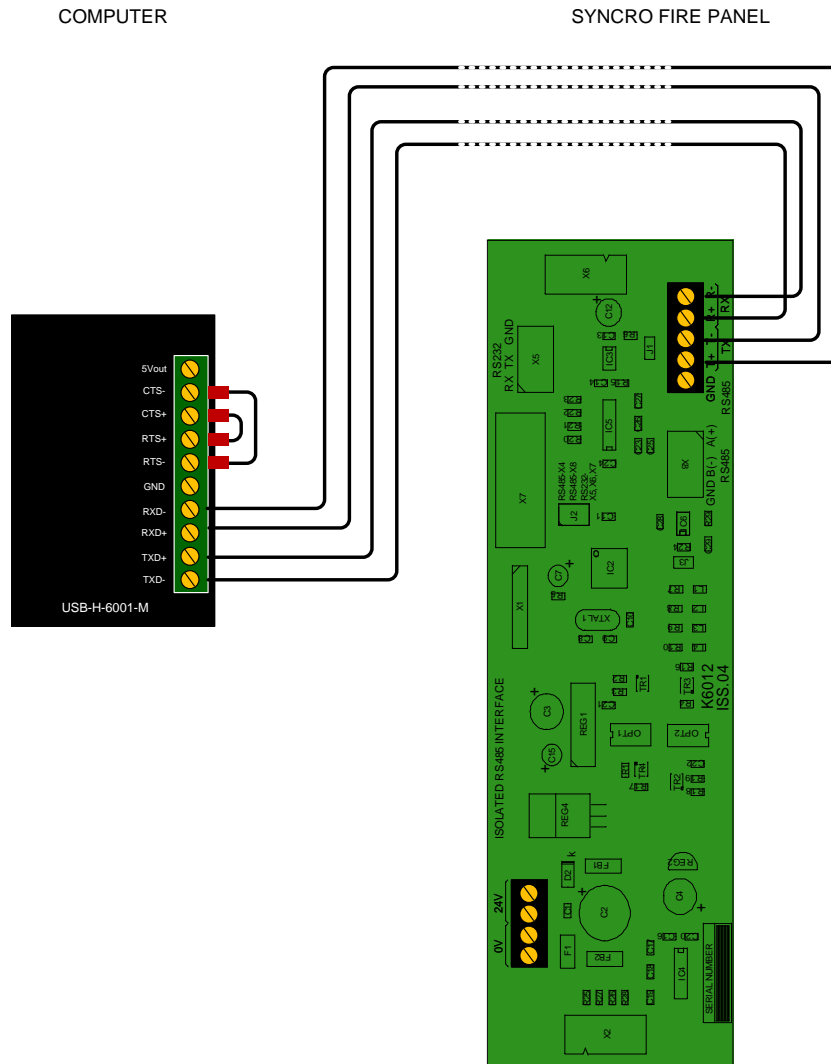

USB2-H-6001-M Connection Diagram

1.2.3 Isolated USB to RS485 (USB485-STI 4W) converter connection

When using the plug-in USB to RS422 converter, connect the converter and to the PC USB port and connect the data cable from the fire panel as follows:

<u>USB /RS422 Converter Terminal</u>	<u>Panel Dongle PCB Terminal</u>
TXD+	R-
TXD-	R+
RXD+	T-
RXD-	T+

Drivers for this converter are supplied on a "business card CD" within the container for the interface. Please ensure that you do not discard this driver CD.

Note: The driver CD requires a CD Rom drive with a centre spindle to allow the CD to be used, as typically found on laptop CD drives.

If the target computer does not have this type of CD drive, it will be necessary to copy these drivers to a USB flash drive before installing the hardware.

Alternatively these drivers may be downloaded from the following web location -

<http://www.hjelmslund.dk/Support.asp>

1.3 Software Installation

PC requirements (minimum)

Processor - Pentium®-class processor, 600 MHz or higher. Dual core supported

Graphics card – 32Mb or better

Monitor – Set to 1024 x 768 resolution as minimum

Operating system - Windows® 2000, XP or Vista (Control panel, user accounts, Select User, properties, Group Membership, select Standard User).

CD Rom media - CD-ROM or DVD drive

Disk space - 25MB of free disk space for simple installation (20 GB recommended if many maps are to be used)

Memory - 512MB of RAM

Insert the CD into the CD Rom drive of the PC and wait for the installation to start. Follow the setup instructions and click “next” to each prompt unless you wish to change any of the folders chosen by GUIDE as default (not normally necessary).

Click “Finish” once GUIDE has installed successfully.

There will now be a new program group (GUIDE) displayed when “All programs” is selected from the Windows® start menu.

Within this program group are six programs, an example project and an uninstaller which will remove GUIDE from the system should you wish to do so.

The four main programs are as follows:

GUIDE Run

The main GUIDE program. This is the application that runs on the PC that is connected to the control panel and displays events to the end user.

BMP Grabber

Utility for use with **Designer** which allows .dxf and .dwg formats to be converted to bitmap format for use with the GUIDE system.

Designer

The designer program to produce project files to be used with **GUIDE Run**.

Used for creating new projects, selecting and editing images, importing the export file from Loop Explorer, drawing zones, placing and setting up device icons and setting up event messages.

Event Log

A utility to filter the event log by date, event type, user or by address. This allows event log interrogation on computers other than the GUIDE target computer.

2.0 GUIDE Run

2.1 Running GUIDE

To become familiar with the GUIDE system, load the sample project, run in simulation mode and generate some events.

From the Windows® start button select All Programs >GUIDE>GUIDE Run.

The GUIDE – Logon dialogue box will be displayed. Click on the User Name field and click Administrator. Enter **Guide**(lower case) as the password then click Logon.

Click on the GUIDE button in the bottom left of the screen and select GUIDE Setup >Guide Settings from the menu that pops up. Click the button marked *find* then click the file *FireX.prj*. Now click Open.

Click OK on the information box which is displayed then click Start Simulation.

The example project is now loaded. The Simulation Mode box can be moved from the centre of the screen by clicking on the bar at the top and dragging to the required position (the top left of the screen is a good place to put it for this demonstration).

The main part of the display shows the overall site with two tower blocks and a third lower level building. Clicking on any of the three buildings will zoom to the appropriate building if required. Clicking on the "Site Map" button will return to the main screen.

Click Activate on the Event Simulator box. The display is now showing a floor plan of West Tower Level 6 and call point activation by the fire exit.

On the left of the screen is a text description of the event with a list of events below (in this case just the fire event we have generated).

Deactivate the event in the Event Simulator box, add a suitably descriptive note in the user comments box in the bottom left of the screen which will be logged with all of the other details about this event and accept the event by clicking Accept FIRE Event at the bottom left of the screen.

We can now leave the floor plan displayed or return to the main map by clicking the Site Map button at the top left of the screen.

The user screen has a number of control buttons located along top. The actual buttons displayed will depend upon the configuration privileges of the user logged onto the system. When logged onto the system as an administrator, all buttons will be available.

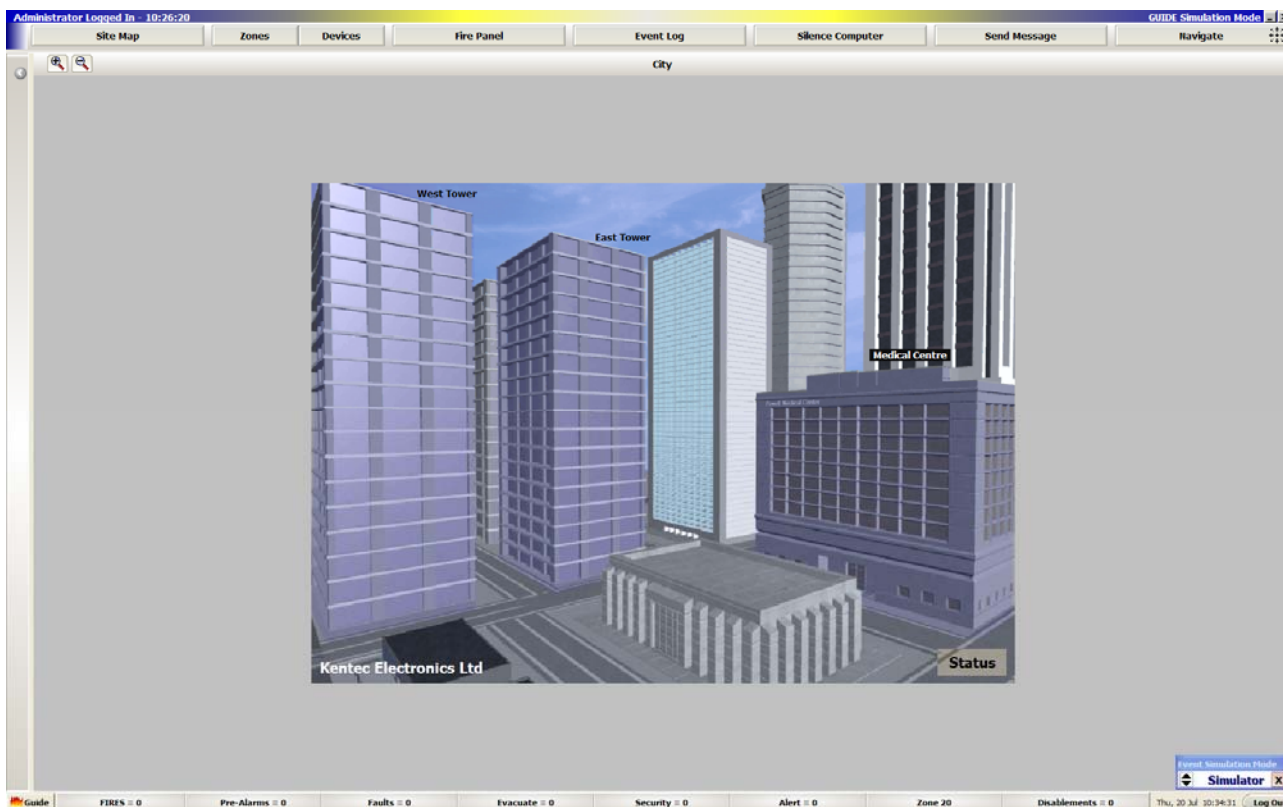

The "Site Map" button will always revert the display to the default image. This same image will also be shown when there are no active events on the system and all events have been accepted.

The "Zones" button will display a grid array showing the status of all the detection zones configured on the system. When in this screen it is possible to select and disable a zone. It is also possible to jump to the "Devices" status grid array from this screen.

The "Devices" button will display a grid array showing the status of all the detection devices configured on the fire system. When in this screen it is possible to select and disable a device and to retrieve the analogue values of detection devices. It is also possible to jump to the "Zones" status grid array from this screen.

The **“Event Log”** button will launch the “Event Log” viewer application. This will allow the event log to be displayed and filtered. The results of the event log search may be displayed as HTML or as List format.

The **“Fire Panel”** button will open a “virtual panel” window. This allows the Guide PC to directly control the Syncro panel to which the Guide system is connected, as if standing in front of the actual panel.

The **“Silence Computer”** button will silence any audible notification of an event. Different audio files may be played for different event actions using the computers audio system. This button will silence any audible events.

The **“Send Message”** button will open the message entry screen. This allows the current person logged onto GUIDE automatically display a message when the message recipient logs onto the Guide system. Typically this is used to pass information to other users, such as reasons for disablements.

The **“Navigate”** button will open the navigation form. This allows simple navigation around the images by use of “North / South / East / West / Up / Down” buttons. This is particularly useful when the site has a large floor layout as it avoids having to zoom out to a higher level map to locate alternative positions on the floor layout.

Along the lower edge of the Run program display there are a number of status buttons. These buttons represent each type of event that may be displayed on the fire system, such as Fires, Pre-alarms, Faults, and Disablements etc. Whenever any active events are on the fire system, the appropriate status bar will be coloured in the configured colour for the event and the number of events of that type will be shown. Clicking on the button will show more details of the events. Clicking on the event will highlight the affected device on the appropriate map image.

If you click on the links on the site map, you can zoom to a floor level image. At this level the detector icons are placed. By clicking on a detector, it opens the device details screen. Using this screen it is possible to disable the device, poll the device analogue value, view the device event history and to view the current state of the device.

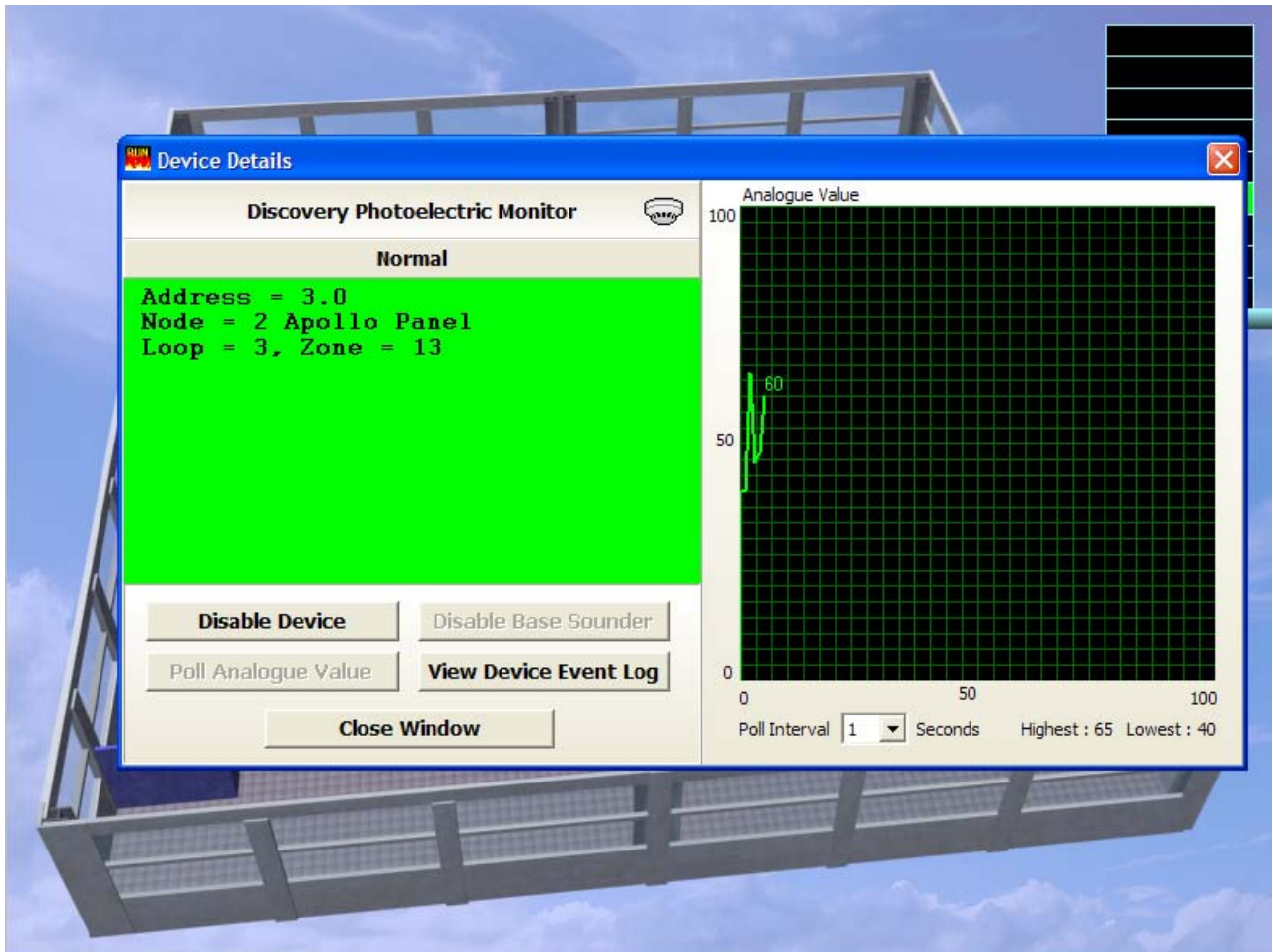

If an image link has a zone allocated to it, then it is possible to right click on the link and then disable and re-enable the zone using this link.

Now that we have seen the basics of what the system can do we can explore the setup in more detail using the example project.

2.2GUIDE Settings

Click on the GUIDE button in the bottom left of the screen and select *Guide Setup* then *Guide Settings*. The following screen will be shown.

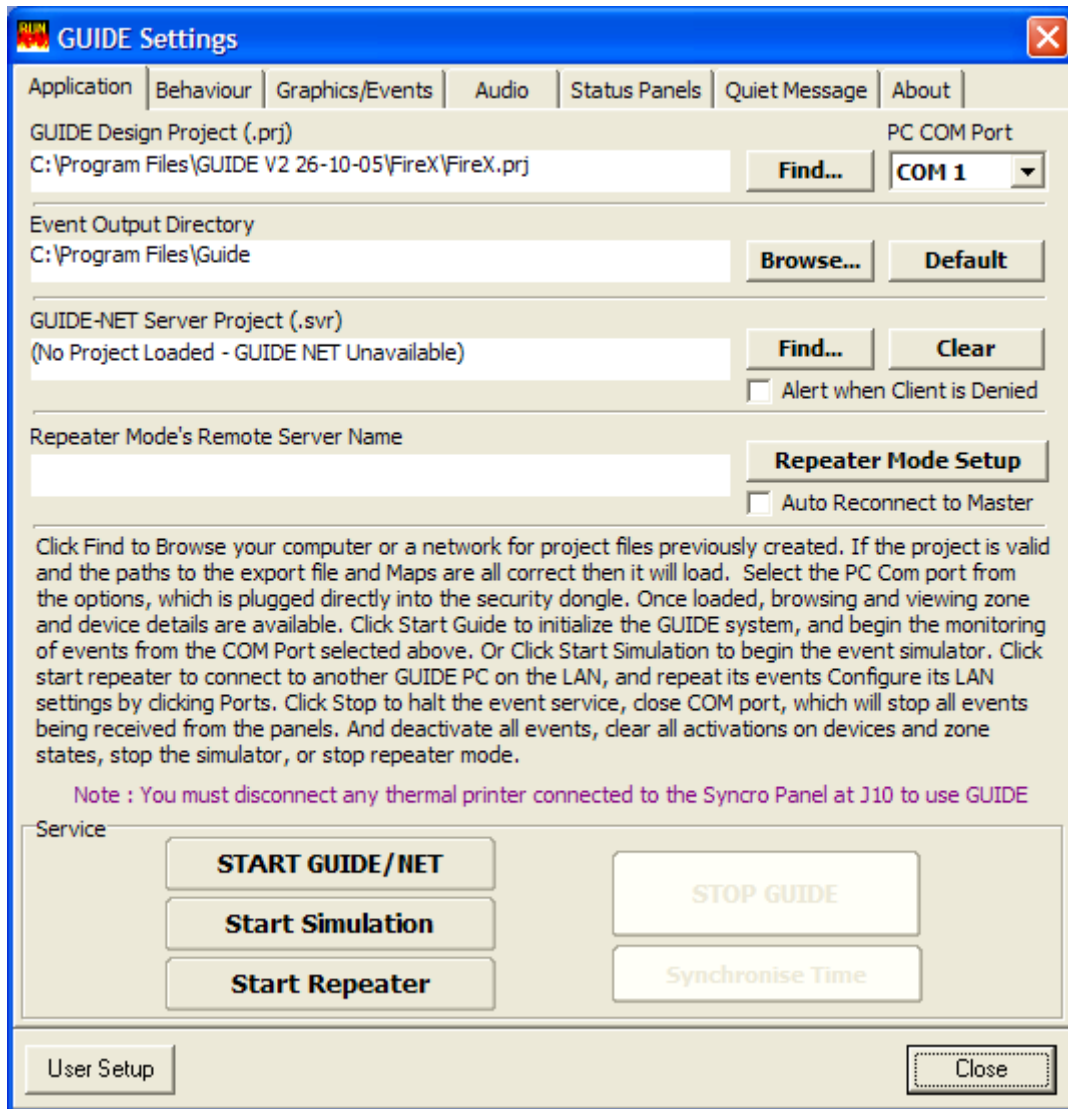

2.2.1 Application tab options

GUIDE Design project (.prj)

This is used to select the site-specific project file. This file coordinates the various image files, detection device icons and location information. This will have been created at commissioning time using the GUIDE Designer application.

GUIDE Design project - Find

This can be used to browse for and load other projects as they are created.

GUIDE Design project - PC port

This is the PC COM port used to directly connect to the GUIDE Dongle installed in the Syncro control panel. The default port is set to COM 1. USB to serial port converters are not recommended for this connection.

Event Output Directory

This is the location of the GUIDE event log files. This may be a local drive location or on a remote server if required.

GUIDE-NET Server Project (.svr)

This feature is not available.

Repeater Modes Remote Server Name

The Guide program may be started as a main program (for the computer linked to the Syncro panel) or as a remote control repeater. The Guide repeater needs to be running on a workgroup or network whereby the repeater computer can access the computer running the main Guide program.

This menu option allows the main Guide computer name to be allocated so that the repeater can get the correct data to display and control the fire system

START GUIDE/NET

This buttons starts the GUIDE when it is connected to a control panel. The GUIDE will not start unless a panel connection is present and the correct security passcodes have been entered.

Start Simulation

This button starts the currently loaded project in simulation mode and can be used without a panel connection for testing and demonstration purposes.

Start Repeater

This buttons starts the GUIDE in "Repeater mode". This is used when the computer is connected to a workgroup or LAN and there is a Guide system running on one of the other computers. Repeater mode will allow the full control and reporting of the Syncro system, but uses the LAN connection via the main Guide system rather than a direct link to the Syncro network.

STOP GUIDE

This button stops the GUIDE from running and is only available after successfully starting GUIDE.

Synchronise time

The time set on the PC can be sent to the panel to which the PC is connected (and all other fire panels if on a network).

2.2.2 Behaviour tab

The main area of this tab is used to select how the GUIDE responds to each of the available event types.

IMPORTANT – The Syncro panel to which the Guide system is connected has to be configured in Loop Explorer to display all events from all other panels on a networked system (network master) AND needs to be configured with a "Graphics Fitted" option selected in the panel settings. The Syncro panel must not have a printer fitted.

GUIDE Settings

Application Behaviour Graphics/Events Audio Status Panels Quiet Message About

Event Type	Processes	Log to file	Force acceptance	Prints	Emails	Nodes to Ignore	Zones to Ignore
Fires	<input checked="" type="checkbox"/>	<input checked="" type="checkbox"/>	<input checked="" type="checkbox"/>	<input type="checkbox"/>	<input type="checkbox"/>		
Pre-Alarms	<input checked="" type="checkbox"/>	<input checked="" type="checkbox"/>	<input checked="" type="checkbox"/>	<input type="checkbox"/>	<input type="checkbox"/>		
Faults	<input checked="" type="checkbox"/>	<input checked="" type="checkbox"/>	<input checked="" type="checkbox"/>	<input type="checkbox"/>	<input type="checkbox"/>		
Disablement	<input checked="" type="checkbox"/>	<input checked="" type="checkbox"/>	<input checked="" type="checkbox"/>	<input type="checkbox"/>	<input type="checkbox"/>		
Alert	<input checked="" type="checkbox"/>	<input checked="" type="checkbox"/>	<input checked="" type="checkbox"/>	<input type="checkbox"/>	<input type="checkbox"/>		
Evacuate	<input checked="" type="checkbox"/>	<input checked="" type="checkbox"/>	<input checked="" type="checkbox"/>	<input type="checkbox"/>	<input type="checkbox"/>		
Security	<input checked="" type="checkbox"/>	<input checked="" type="checkbox"/>	<input checked="" type="checkbox"/>	<input type="checkbox"/>	<input type="checkbox"/>		
Tech Alarm	<input checked="" type="checkbox"/>	<input checked="" type="checkbox"/>	<input checked="" type="checkbox"/>	<input type="checkbox"/>	<input type="checkbox"/>		
Test Mode	<input checked="" type="checkbox"/>	<input checked="" type="checkbox"/>	<input checked="" type="checkbox"/>	<input type="checkbox"/>	<input type="checkbox"/>		
Status	<input checked="" type="checkbox"/>	<input checked="" type="checkbox"/>	<input checked="" type="checkbox"/>	<input type="checkbox"/>	<input type="checkbox"/>		
C&E Action	<input checked="" type="checkbox"/>	<input checked="" type="checkbox"/>	<input checked="" type="checkbox"/>	<input type="checkbox"/>	<input type="checkbox"/>		

GUIDE Behaviour Note: Each event has a group, listed above, the behaviour of GUIDE upon receiving an event of each type if ruled by the checkboxes within the columns adjacent to the events. Force Acceptance makes the user accept each event, whether it is active or not, and will only be available if GUIDE Processes the event type. The Nodes/Zones to ignore columns should be used if GUIDE needs to ignore certain node addresses or zones for each event type. The values in these columns should be comma separated i.e. 1,2,4 will make GUIDE ignore events from nodes addresses or zones 1 2 and 4, for the particular event type.

Archive Event log file
 Current File: GUIDE-10-57.6.12.2004.lst
 Start a New Log File Every 4 Weeks

Analogue Value Charting (Master Only)
 Take Sensor Readings Every 10 mins
 Take Reading Now Clear

Printing Options
 Print outs will be sent to the default
 Print Map Screen Shot with Event
 Print Event Text

Additional Text (Added to bottom of sheet)

User Setup Close

Processes

If this box is not checked these event types will not be displayed but still can be logged, printed and emailed.

Logged to File

If this box is not checked these events will not be logged to the computer event log file.

Force Acceptance

If this box is not checked an event that is cleared (by resetting the fire panel for example) will automatically clear from the text display on the left of the screen and will not need to be accepted.

Prints

If this box is checked events of this type will be printed to the Windows default printer connected to the PC or LAN.

Emails

If this box is checked events will generate an email to be sent to selected recipients (see Graphics/Events tab for details).

Nodes to ignore

In networked systems, which may cover different buildings with different security centres, it may be advantageous to select all events from certain panels (nodes) to be ignored. The nodes to be ignored should be entered with comma separators i.e. 1,2,4

Zones to Ignore

Likewise it may be beneficial to ignore events from specific detection zones. Entering the zones to be ignored using commas to separate entries performs this.

Archive Event Log File

The Event Log record is made of a number of files which are automatically created at regular intervals. The frequency at which a new file is created is selected using this option. Such a facility allows part of the event log to be archived by removing only the oldest files that are used to create the overall event log information.

Analogue Value Charting

This beta facility is to allow analogue values of all detectors to be recorded and saved at regular intervals, for future interrogation.

Printing Options

When the "Print" behaviour has been selected for an event type, then it is possible to select whether a screen shot giving the highlighted device is printed and / or whether the event text information is printed. There is also the facility to add some specific text at the bottom of the printout, for example filing instructions or site procedures.

2.2.3 Graphics/Events tab**2.3.3.1 Screen Layout Tab****Map Background colour**

Allows the background colour of the main display area to be selected from a palette of common colours or whether to automatically select the colour according to the corner colour of the map image. The background colour is only visible if the image files do not fill the full screen size.

Show Device Address Labels

Permanently displays the address label information for any detection devices visible on the selected map. If this is not selected the device information is only visible when the cursor is selected over the device icon

Map Navigation Border Buttons

If the site configuration file has been developed using navigation from one image to the next, then rather than use the "Navigate" button to open the navigation form, it is possible to click on the map border to move to the next image. Therefore clicking on the left frame of the image will scroll to the next image to the West of the current one, if this is enabled.

Navigation Transition Effects

Selecting this option provides a smoother transition between map images when navigating between images old older, slower computers. On modern computers, the transition is sufficiently quick to ensure that this would not be visible.

System Status in Map Windows

When selected, this option will show high priority information messages in the main map screen area. In particular, the "System Offline" message becomes very obvious when this option is selected.

Event Pane Layout

The event pane is normally selected to the left of the computer screen. However it is possible to adjust the location of the event pane to the right or lower part of the computer screen, if desired.

Mouse only / Touch screen

When selected the Guide system will support a touch screen only option. In this mode, the virtual keyboard icon is present when logging into the Guide system and when accepting events, thus eliminating the use of a conventional keyboard for typing messages.

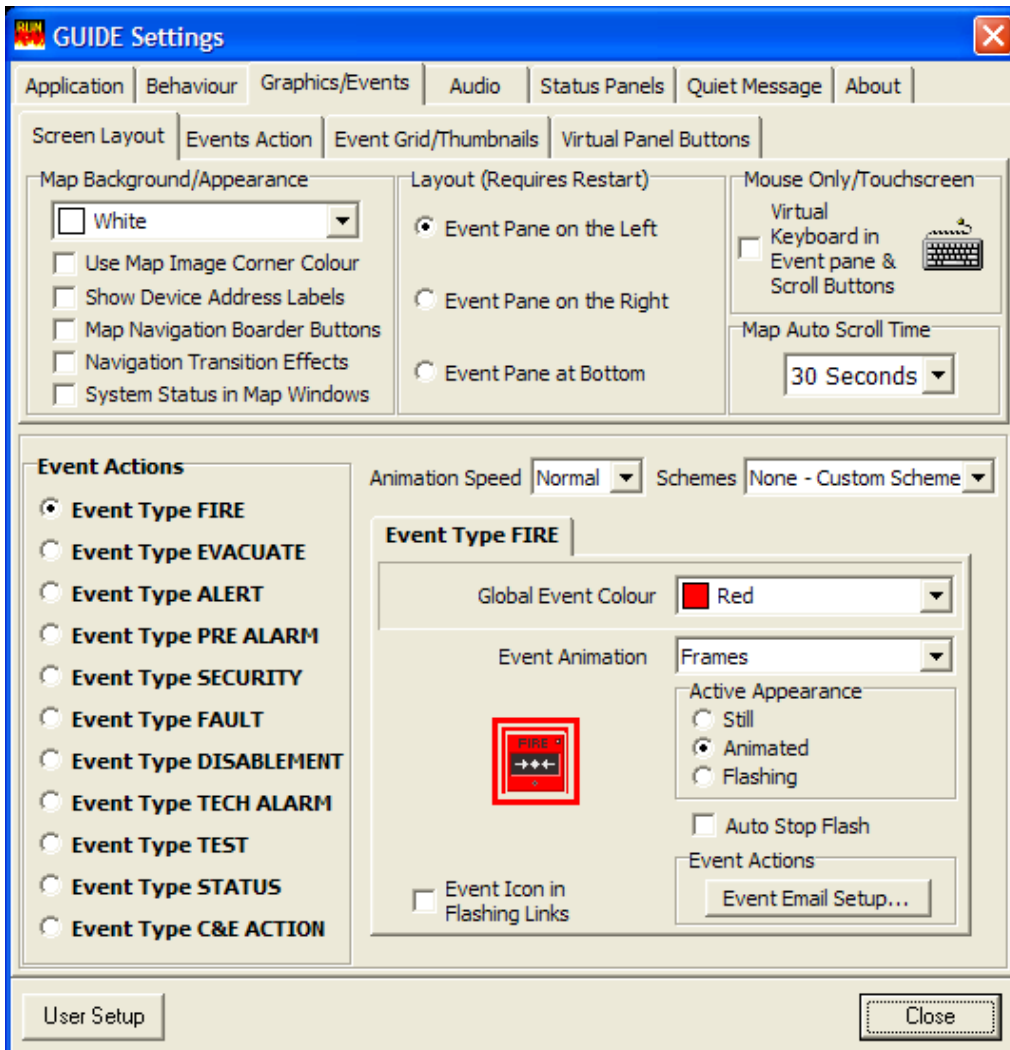

Map Auto Scroll Time

If more than one event is present and the events are on different maps GUIDE can be configured to scroll between all active maps. This setting allows the scroll time to be set between 5 seconds and 1 minute or turned off completely.

Event Action Settings (Shown for all tab options)

For each event type various graphics effects can be assigned using the following settings:

Animation Speed

When using animated icons, the speed of the animation may be selected (Slow, Normal or Fast)

Colour schemes

Schemes are selectable which change the colours and animations of each event type globally.

Global event colour

The colour of the animation surrounding an activated device can be changed.

Event animation

The animation effect surrounding an activated device can be changed.

Active Appearance

The highlighted icon may be selected to animate, flash or have a steady highlight

Event Icon in Flashing Links

This option will show the event type icon in the higher-level images, which only have links to the map where the event has occurred. These links will normally also be highlighted to the colour of the event as well.

Auto Stop Flash

This option will automatically stop the flashing of detector icons when an event has been accepted.

Event actions

This allows one or more email addresses and message body text to be added so that events that are checked to send emails in the Behaviour tab are emailed to the desired recipients.

2.3.3.2 Events Action Tab

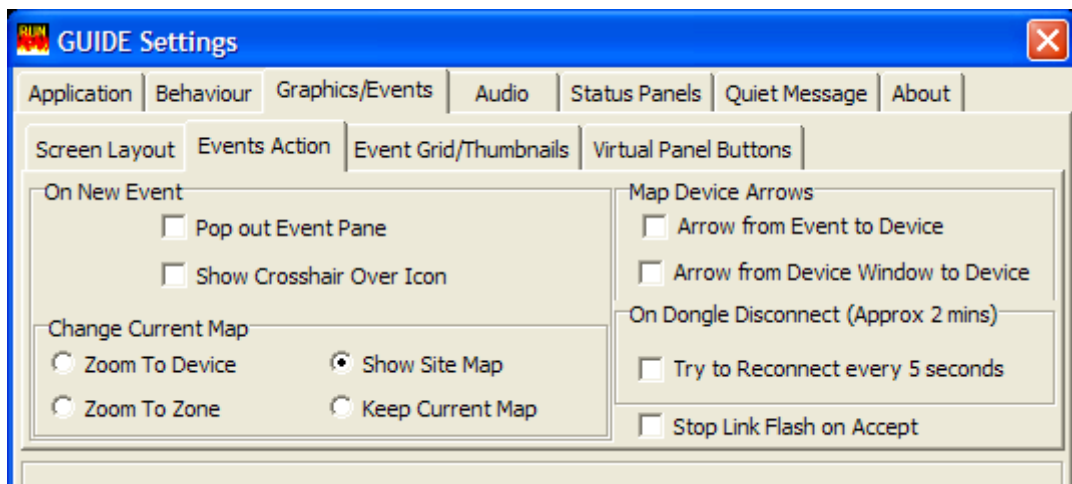

On New Event

Here it is possible to select if the event pane is automatically displayed when an event occurs. There is also an option to highlight the new event by means of crosshair lines when the event occurs.

Change Current Map

When a new event occurs there are options to determine the response of the Guide system. The choices are to zoom to the device, zoom to the map with the zone link of the zone of the event occurrence, keep the current image or revert to the top level site map image.

Map Device Arrows

Arrow from event to Device

When a device is selected in the Event Pane, an arrow is automatically generated to point to the selected device.

Arrow from Device Window to Device

When a device icon has been clicked on, the Device Details screen is shown as detailed in section 2.1. If this tick box is selected then an arrow is shown from the Device Details screen to the selected icon.

On Dongle Disconnect

This allows the system to try to reconnect to the dongle every 5 seconds when selected (recommended)

Stop Flash Link on Accept

When selected, links to the active event will no longer flash when the event has been accepted

2.3.3.3 Event Grid/Thumbnails Tab

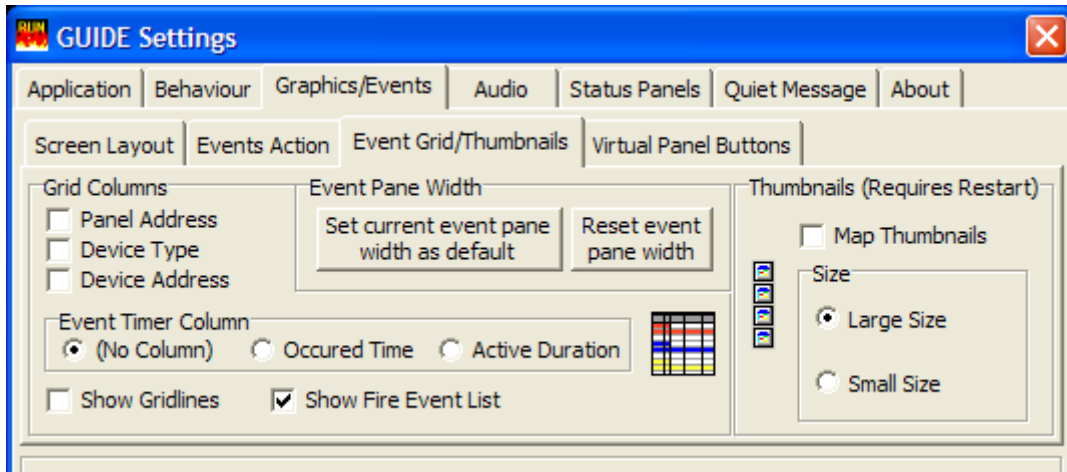

Grid Columns

This allows the user to configure what information is shown in the event pane tree view. Three of the options can be selected / deselected. The fourth column(event timer column) can be configured to be either hidden, time of occurrence or the duration since the event occurred.

Event pane width

It is possible to configure the width of the event pane. This is occasionally required if large fonts are used in the event pane, or if unusual screen resolutions are configured. Manually clicking and dragging the event pane to the required width can set the configured width set as default.

The Reset even pane width button restores the width to the default setting

Event Timer Column

This allows the fourth column in the Event Pane view to be configured. This column can be configured to show nothing, or can be configured to show the event time of occurrence or time since the event occurred. The latter is useful in systems with delays to outputs, as it shows how much time since the event occurred and therefore how much time is left.

Thumbnails

This option allows a thumbnail image of every map in the project to be shown in a scrolling column to the right hand side of the screen. These thumbnails can then be used to easily navigate to other maps if required. If selected, the Guide system will need to be re-started before this change takes affect.

Show Gridlines

This allows gridlines to be displayed between the grid columns in the event pane tree view grid

Show Fire Event List

This option will allocate a separate section in the event pane, above the tree view area, where just FIRE event information is shown. This is particularly useful on installations where there may be many active disablements at any one time, because the fire events are immediately visible.

The screenshot shows a software interface for monitoring events. At the top is a table titled 'Current Events' with columns for Event, Node, Loop, Zone, and Time. Below the table is a tree view of event types, including 'FIRES (2)', 'Pre Alarms (1)', and 'Faults'. The 'FIRES (2)' section is expanded, showing two individual fire events with a fire icon. The 'Pre Alarms (1)' section is also expanded, showing a pre-alarm event with a fire alarm bell icon.

Current Events				
Event	Node	Loop	Zone	Time
FIRE	1	1	75	16:55:51
FIRE	1	4	5	16:56:21

Event Type

- FIRES (2)
 - FIRE
 - FIRE
- Pre Alarms (1)
 - Pre Alarm
- Faults

2.3.3.4 Event Grid/Thumbnails Tab

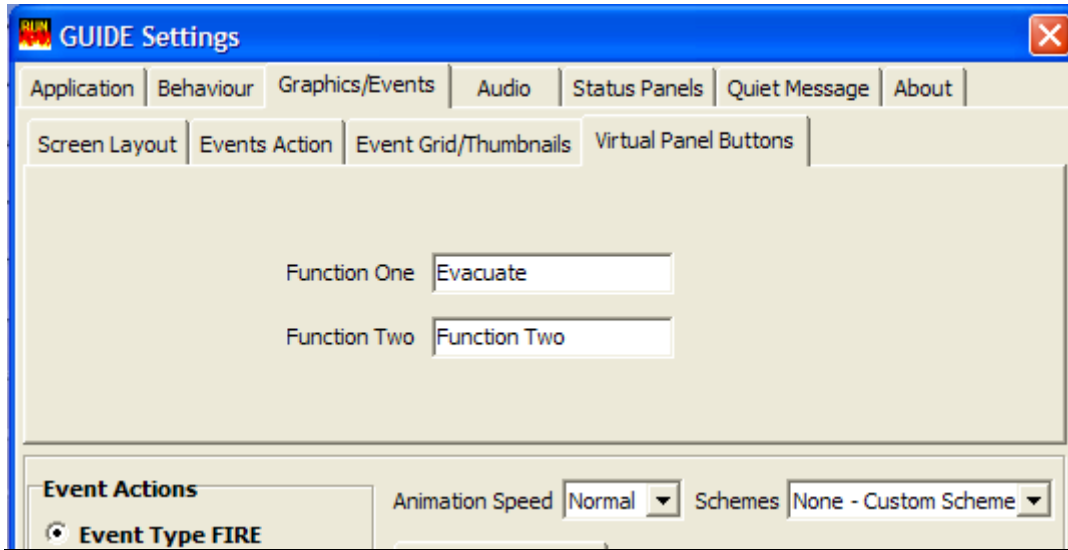

Function One / Function Two

Here it is possible to allocate text against the two function buttons in the Virtual Syncro panel screen (accessed by the "Fire Panel" button on the top of the Guide screen. This is particularly useful if these have been configured for a specific function such as "Evacuate" or "Performance Mode" for example.

2.2.4 Audio tab

This allows different sounds to be added to each event type. The sound can be selected to play once or repeat until the event is accepted. A useful source of sounds can be found within Windows® at C:\WINDOWS\Media folder on the computer.

Other sounds can of course be used, including voice. Voice messages of up to 60 seconds long can be recorded using the Windows® sound recorder

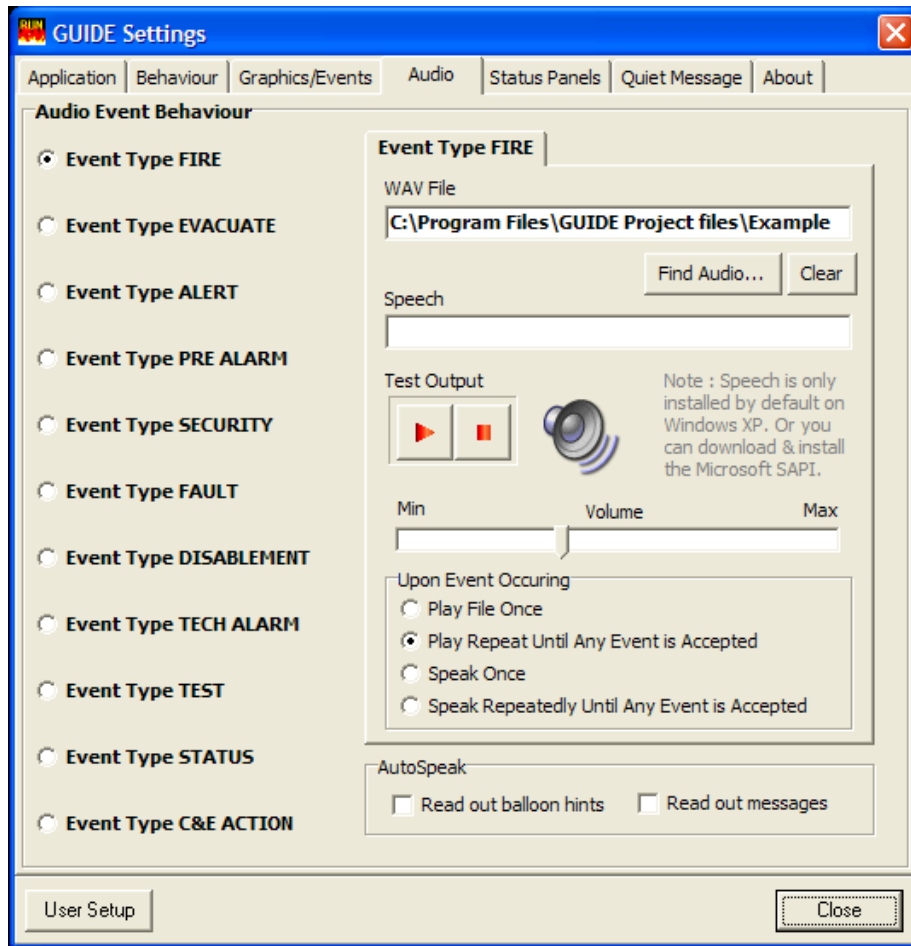

Each event type can also be announced using either the selected wav file or by synthesised speech. If the speech option is required, type the message in the “Speech” message box.

Different audio files or speech messages may be allocated to different event types. This allows priority events, such as the fire event colour to be easily identified by the audible indication alone and to attract the attention of the user when such an event occurs.

Test Output

This allows the selected audio file or speech message to be tested. If the “repeat until accepted” option has been selected, then it is possible to stop the test using the right-hand button.

Volume

The volume of the audio file or speech message may be adjusted to this pre-configured setting.

Upon Event Occurring

Allows the audio file or speech message to be played repeatedly (until silenced using the button at the top of the screen) or to play just once. Typically and audiophile will be configured to repeat until accepted.

Auto Speak

Configuration options to allow the speech synthesiser to read out any messages in the run program as they occur, was read out any hints when a particular item is highlighted.

2.2.5 Status Panels tab

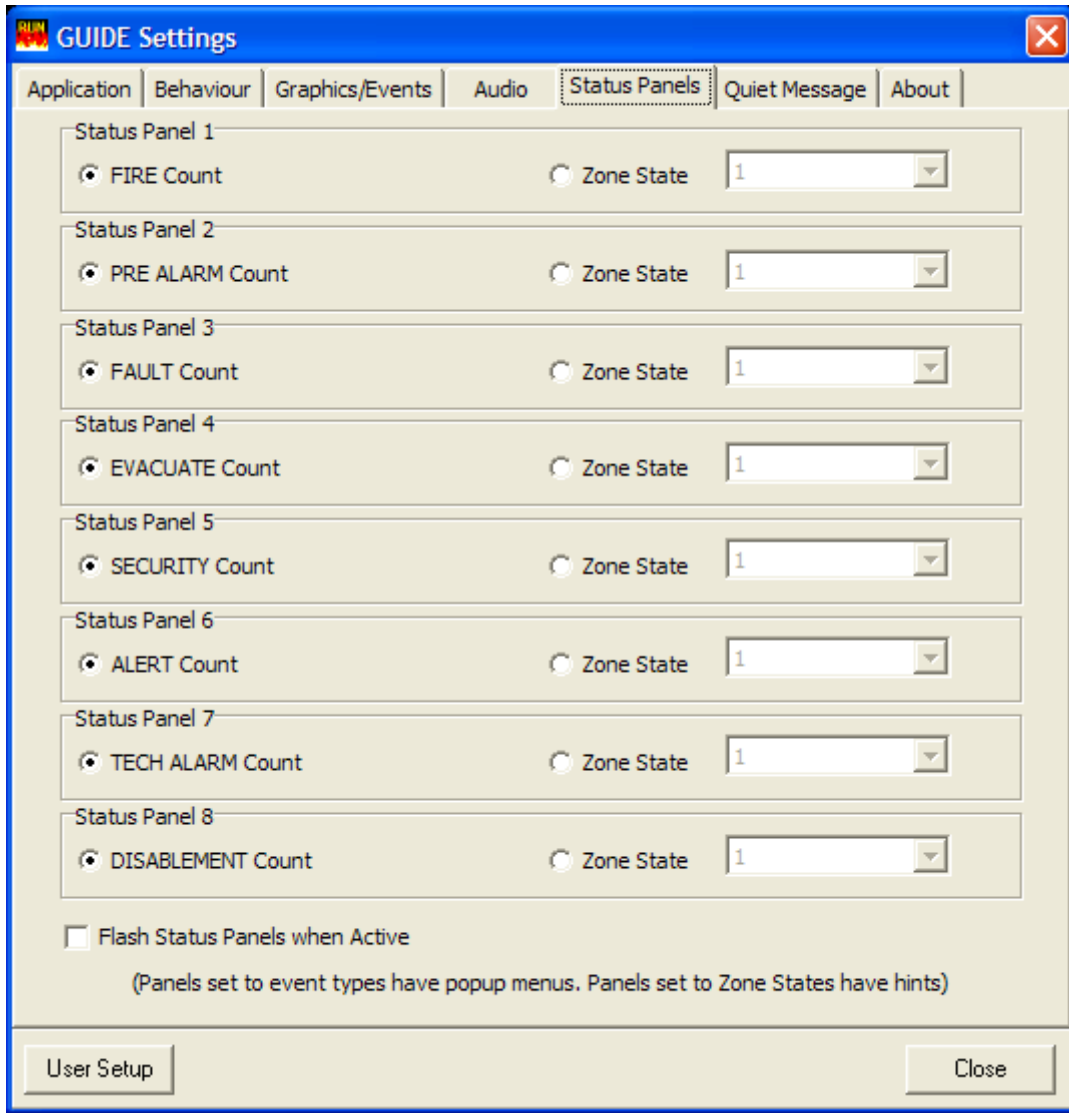

The status panels are the "information buttons" seen at the bottom of the normal operating screen. Under normal circumstances, these buttons show the number of active events for each event type. It is possible to customise these buttons to show the state of a particular zone on the fire detection system. This may be useful on installations where there is a high risk or particularly sensitive area within installation.

Flash Status Panels When Active

When this option is selected the status panels at the bottom of the screen will flash with the appropriate colour configured against the event type.

2.2.6 Quiet Message tab

A message can be added and displayed at the top of the side pane. This will only appear when the GUIDE is connected to a control panel and running.

2.2.7 About tab

This will show the version of theGUIDE Run software and additional computer system information.

2.3 User Setup

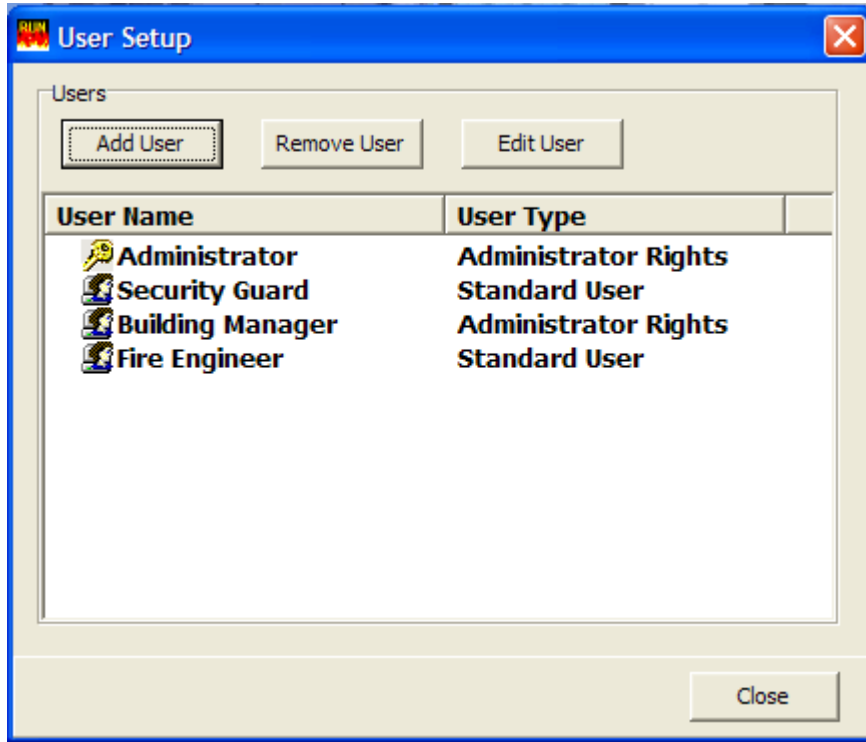

Once the system is configured and installed it may be desirable to restrict some functions so that end users cannot change settings, which could prevent the system from presenting the desired information.

Click the GUIDE button in the bottom left hand corner of the screen and select User Setup, the second item from the top of the menu that pops up. Alternatively, click on the " User Setup" seen in the lower left corner of any of the Guide Settings screens, as shown above.

On a new installation there will be only one user allocated. This will be the Administrator account, with the default logon pass code of "GUIDE". This account may be edited, but not deleted. **At least one administrator account is required, but more administrator level accounts may be generated if required.** Up to 12 different accounts may be generated.

Add User

Clicking on the Add User button opens the user setup form.

User Name

Enter the name of the user or a common user name, for example "Security Guard" into this space. This name will be seen on the login screen when the Guide program is started.

Password

Type the User Specific Password in this space and retype the password to confirm.

Test/View Password

This allows previously configured passwords to be viewed.

Automatically log in use off after....

When selected this option will log off the user after the defined period of inactivity. This ensures that only the correct user is logged onto the system and that the system is in a safe state when no users are present.

Administrative Privileges

When this option is selected, the user has full administrative privileges, including the ability to close down the application and to amend users and configuration options. This option should only be selected for trained members of staff.

Start GUIDE Service On User Login

in the event of a computer restarting, when this option is selected the link to the four detection system will be established at the points when the user logs into the Guide system. This avoids the need for an administrator to start the GUIDE service. **It is recommended that this option is selected for all users.**

When developing the Guide configuration program in simulation mode, it may be preferable to remove this option to avoid the Guide system from trying to connect to the Syncro control panel.

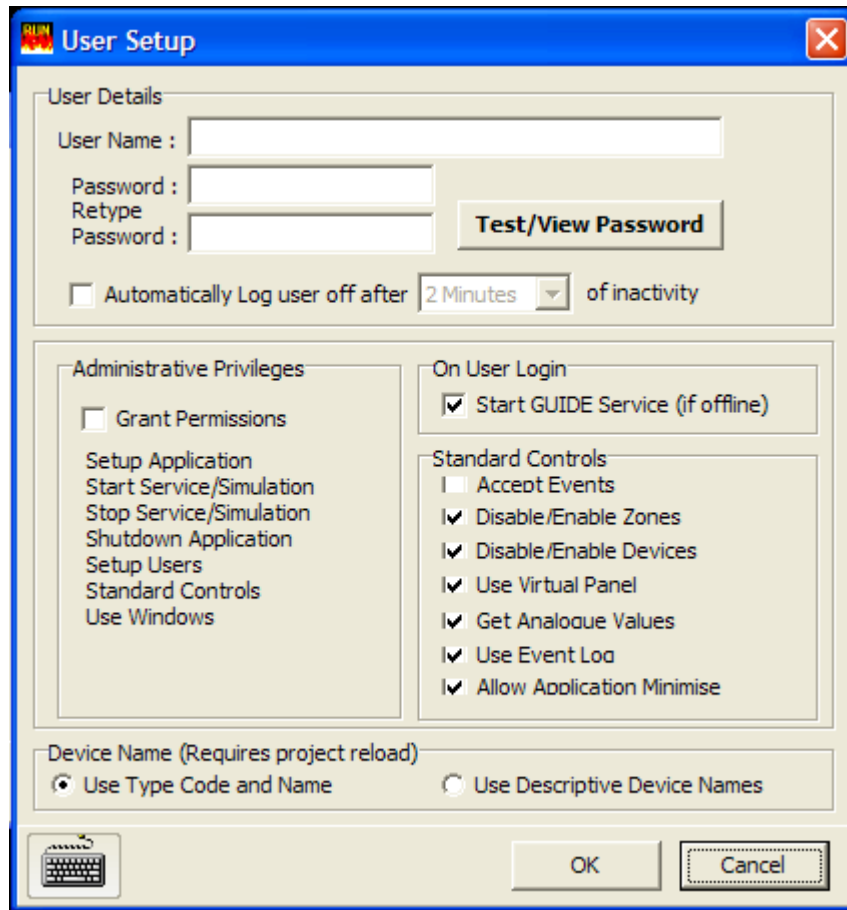

Standard controls

Deselecting these options places restrictions on the features available. When deselected, the appropriate function is removed from the Guide run program, rather than being "greyed out".

The "Allow application minimise" option should be deselected in most cases, as this allows the program to be minimised and other programs to run on the Windows environment. The recommended use of Guide is to be the exclusive program running on the computers.

Device Name

In numeral a room the Guide run "Devices" screen there is the option to show simple device names, such as smoke detector, heat detector etc or to show descriptive device names such as photoelectric smoke detector, ionisation smoke detector.

The latter will include the manufacturers part reference and is suitable for users are familiar with these devices.

The Guide system will need to be restarted before this change comes into effect

Edit User

This button allows the facility to use the details to be amended. The options the global are identical to those for the "New User" facility above.

Remove User

Allows existing user accounts to be deleted. At least one administrator account must exist.

2.4 Security Code

In order for the Guide program to communicate with the Syncro control panel(s) it is necessary to request the Guide unlock code.

Before you start

You will need your Purchase Order reference and company details before contacting the Kentec sales department for your unlock code.

Requesting an unlock code

Click the GUIDE button in the bottom left hand corner of the screen and select the "Security Code" option, to view the Security Code Wizard.



Read Dongle Code

If a security code already exists on the Guide system, then details of the number of panels unlocked, purchase order code and custom reference will be given on the security dongle code form above. Click on the Read dongle code button to refresh this information.

Get New Dongle Code

- 1) If the dongle is new (i.e. it has not been programmed before) click on the Get New Dongle Code button.
- 2) The hardware will be interrogated and a code number will be displayed. Note this code number.
- 3) Send this number to the Sales department at Kentec Electronics Limited, along with your company details and the purchase order details under which the product was supplied. This may be by e-mail (sales@kentec.co.uk), by fax or by telephone contact.
Note: The number can be copied to the clipboard so that it can be printed using a text editor or emailed directly to Kentec Electronics Ltd.
- 4) The sales department at Kentec will use the code supplied and order information to generate a unique unlock code, which can be issued by telephone or emailed back.

Authorise Code

When the unlock code has been issued by Kentec, click on the "Authorise Code" button and follow the on-screen instructions to enter the new unlock code.

Press Authorise and the dongle is now authorised (for use with this installation only).

2.5 GUIDE Service

Click the GUIDE button in the bottom left hand corner of the screen and select User Setup, the fourth item from the top of the menu that pops up. Three additional options are presented.

Start GUIDE Service

This will start the GUIDE in normal running mode but only when correctly connected to a control panel and with the dongle code enabled. Starting the GUIDE Service when not connected to a control panel or with an incorrect dongle code will result in an error message.

Start Simulation Mode

This will start the GUIDE in simulation mode as described in the earlier section **2.1 Running GUIDE.**

Stop Active Service Mode

This will stop a running GUIDE service.

2.6 View Maps

Click the GUIDE button in the bottom left hand corner of the screen; select the "Screen" option, then View Maps.

This will show the list of maps in the currently loaded project. Clicking on a map icon will display it in the main display area of the screen.

2.7 View Loop Devices

(also available via "Devices" button at top of main screen)

Click the GUIDE button in the bottom left hand corner of the screen; select the "Screen" option, then select View Loop Devices.

All devices in the current project can be viewed in a resizable window in a table format as follows:

Device icon
Device type
Node (panel to which the device is connected)
Loop
Address
Zone
Location text
State (normal/activated)
Disabled (with check box to disable if GUIDE is running)
Base sounder fitted
Analogue value of device (if GUIDE is running)
Maps on which the device is located

There is also a button in this window to view the states of each zone showing the number of active events of each type and options to disable zones or put them into test mode.

A further button is provided to refresh the analogue value information.

2.8 View Zones

(also available via "Zones" button at top of main screen)

Click the GUIDE button in the bottom left hand corner of the screen; select the "Screen" option, then View Loop Devices.

The status of each zone is displayed in a table format. All zones except zone 0 can be disabled.

2.9 Print Current Event

Click the GUIDE button in the bottom left hand corner of the screen; select the "Events" option then "Print Current Event".

By selecting Print Current Event an active event can be printed to the default printer. To print other active events select them and select Print Current Event again.

2.10 Event Log

(also available via Event log button at top of main screen)

Click the GUIDE button in the bottom left hand corner of the screen; select the "Events" option then "Event Log".

The event log is displayed in HTML format in a resizable window. The event log can be changed to a text list view, saved to disk, printed or email via the buttons at the top of this window.

By selecting the New Search button the event log can be filtered By event type, user, date, node, loop, zone, address or device type or any combination of these. This powerful filter helps produce data, which can be analyzed, to track down repeated activations and is a valuable tool in the fight against false alarms.

2.11 Map Windows

Click the GUIDE button in the bottom left hand corner of the screen; select the "Screen" then select "Map Windows".

Three additional options are presented.

Tile Horizontally

Displays all active maps on the screen horizontally.

Tile Vertically

Displays all active maps on the screen vertically.

Cascade

Displays all active maps on the screen laid one on top of the other.

2.12 Minimise (to use Microsoft Windows)

Click the GUIDE button in the bottom left hand corner of the screen; select "Screen" then "Minimise Guide".

This minimises the GUIDE application to a small grey bar in the bottom left of the screen so that other Windows® applications can be used while still running GUIDE.

An option to continue to show a summary of events is also possible with this option (Minimise Guide with Tray Status)

To re-instate GUIDE as the main viewable application, double click on this grey bar.

2.13 Log off Administrator**(also available via Log Off button at bottom right of main screen)**

Click the GUIDE button in the bottom left hand corner of the screen and select "Log Off Administrator".

This will log off the administrator and presents the GUIDE – Logon box to allow other users to log on.

2.14 Shutdown GUIDE

Click the GUIDE button in the bottom left hand corner of the screen and select Shutdown GUIDE from the bottom of the menu that pops up.

Shuts down the GUIDE application.

2.16 Side bar (Event Panel)

To supplement information displayed by way of maps, diagrams or photographs, a side bar appears whenever an event is activated.

The top of the side bar shows the event type and the following information as it has been formatted in the Designer programme.

Node number (or if the panel has been programmed with a panel name the panel name will be shown).

Zone number (and zone text if this has been added in the Designer program).

Address number and loop number

Device type

Specific user text that has been added in the Designer programme.

Below the main event text window is a status window where a list all active events is displayed. These can be accepted individually by selecting the event and clicking Accept.

3.0 Designer

Before a GUIDE design project can be created you should have a Loop Explorer ".lx2" file and some maps in Bitmap/ JPEG / TIFF / GIF / WMF format in a convenient location so that they can be imported.

Loop Explorer is the fire control panel configuration utility used for configuring Syncro fire panels.

A .lx2 file can be created from within Loop Explorer by selecting "Export Loop Explorer config." from the "File" menu and saving it to a convenient location.

For training purposes, the files from the example project at **c:\program files\GUIDE\example project** can be used.

Here you will find a .lx2 file called FireX.lx2 and a number of map images.

To start the Designer program click the Windows start button, click programs, click GUIDE and then Designer.

Click "Start New GUIDE Project", then "OK", then enter a project name and save the project to a location where it can easily be found later.

When the Map Wizard appears after saving the project, select Next then select the maps you wish to import into the project (the maps at **c:\program files\GUIDE\example project** can be used for training purposes) then click next again.

Here you can give each map a name that is different to its original name if required and select one of the maps to be the main site map.

The main site map will be displayed on the screen all the time the GUIDE is running with no events that call other maps.

Click next then select the Loop Explorer .lx2 file you wish to use for this project. (the .lx2 file in the sample project can be used for training if required).

Click next and the main design screen will displayed showing the main site map with Project navigator and Network Navigator on the left.

Each of the maps can now be viewed by selecting them from the Project Navigator window on the left of the screen and the fire alarm devices that were imported from the .lex file can be viewed by expanding the control panel icon in the Network Navigator window below the Project Navigator window.

The vertical toolbar is for re-sizing zones (the first 8 tools) and nudging the position of placed icons (the last 4 tools).

3.1 Allocating zones and map links

Before any devices can be placed, zones need to be added to the maps.

Select a map from Project Navigator that is the most detailed. (The one that will show activated detectors and calls points etc.)

When the map is displayed, right clicking it will display a menu from which Background map options can be selected.

From the Map Details tab, the name of the map can be changed, a different map can be selected; the map can be shown in Negative Image or in grey scale or the map can be edited by selecting Edit Picture. This will load GUIDE Draw, depending on file type – a simple picture-editing tool, otherwise it will load Windows Paint. (Select File> Exit to exit the picture editor).

The Map Size tab allows the map to be re-sized for the best fit on the screen. Selecting the Lock check box when re-sizing will keep the proportions of the map consistent.

The Grid Size/Nudge tab allows a grid to be displayed from 4 to 80 pixel spacing by adjusting the Grid Spacing slider. The Snap to Grid check box gives the option to have the zone areas that are drawn to snap to this grid.

The Icon Nudge Distance can also be set between 1 and 50 pixels using the slider.

Icon Nudge distance, is the distance an icon will move when nudged using the icon tools on the toolbar that runs vertically up the screen.

Once the Map Options have been set, click New Link/Zone from the menu bar at the top of the screen. The cursor will change to a multi-directional arrow with a 'Z' by it if it is a Zone, otherwise it will be 'Link'.

Click on an area of the map where the zone area is to be drawn. This will show the Clickable Area Options editor.

3.2 Drawing and linking zones

Map Links

Map links are used to allow zooming in or out to show more or less detail. For instance, the GUIDE may be monitoring a number of buildings on a large, widely spread out site as is found in some hospital complexes.

In this instance the main site map would ideally be a map showing the whole site including individual buildings being monitored.

Each of those buildings could have a link to it on the main map which when clicked would display an overall plan of the building. It may well be that the building is too large to show the detail that may be needed in a fire situation and further links to more detailed areas of the building may be added.

A button at the top of the screen labelled Site Map allows navigation back to the overall picture and zooming into other areas.

To set up a map link select New Link/Zone from the top toolbar and click on an area of the map. From here the zone can be configured to zoom in or out when it is clicked. Select zoom out and choose the map you wish to zoom out to.

Zone options

Choose a zone number from the lower half of the window.

Under Caption Details enter any text and choose the font and justification that you wish to be displayed within the boundaries of the zone.

The Shading box allows the fill style of the zone area to be solid or striped with coloured lines with an option to display the caption on a solid background.

Borders can be shown around the zone and the colour and width of them can be chosen.

The Fill Colouring of the zone can be chosen to suit the background on which the zone is displayed. For instance a red zone on a red background would not be seen.

The default colour of the zone area can be chosen and customised using the colour swatch.

Fill Colouring allows the zone to be displayed in a variety of ways to suit the background on which the zone is drawn.

Having set the properties of the zone, click OK to draw the zone area on the map.

The zone area will be shown as a square with four handles, which can be dragged in any direction to make larger regular or trapezoid shapes.

For creating areas with more than four sides additional nodes can be added using the Add Nodes button. Nodes must be added between the two green handles. They can then be dragged into position as required.

Click the Add Nodes button to turn it off when the required nodes have been added.

Adding nodes allows any polygon to be drawn with a reasonable degree of accuracy.

The eight icon tools in the vertical toolbar can be used to adjust the area of the zone in any direction for fine tuning the drawing.

The zone that we have just drawn will now be shown in the Project Navigator on the left under the map on which it is drawn.

The properties of the zone (colour, fill style etc) can be changed by right clicking an area within the zone and choosing Zone Options.

Test Map Link

The map link can be tested by right clicking the map and selecting Test Map Link. To revert back to the map you were working on select it from Project Navigator on the left of the screen.

Transformations

Zone areas that have been drawn can be modified by right clicking within the zone area and selecting Transformations from the menu. This allows the zone area to be placed in front of or behind other zone areas or flipped horizontally or vertically.

Lock

Zones that are complete and require no further modification can be locked against further editing by selecting Lock from the right click menu. They can also be unlocked by selecting Unlock from this menu.

Duplicate

Zone areas that are the same size and shape can be produced very quickly by drawing one and duplicating it by right clicking the zone and selecting duplicate. Duplicates can be modified if required by right clicking them and selecting zone options.

Delete

Zones can be deleted by selecting them, right clicking and selecting Delete.

Zone text

Zone text can be added to all zones once they have been created by selecting the Zone Text button from the top tool bar.

Zone text is displayed next to the zone number in the text pane when an event is activated.

3.3 Adding devices to maps

The Network Navigator on the left of the screen shows all of the control panels on the fire alarm panel network. Click on the + sign next to the panel to expand the view then click on the + signs next to the Loops, Panel I/O or I/O boards to see individual devices and inputs or outputs.

The Zone Placement tab at the bottom of the network Navigator window will show all of the devices sorted into zones. Select this view to add devices to zones.

To add a device to a map, select Zone Placement view and click the + sign next to the zone number to be configured. This will show all devices that have been put into that zone by the .lex file.

To place a device, click on it and with the mouse button held down; drag it into the zone on the map to a position, which is representative of where the device is installed.

To place many devices, hold the CTRL or Shift key on the keyboard and click multiple devices and then drag and drop onto the map.

Using the four icons at the bottom of the vertical toolbar a selected device or devices (shown by a blue box & selected by drawing an area around them or clicking whilst holding CTRL) can be nudged in any direction to position it more accurately. Right clicking the zone, selecting Background map options and adjusting Icon Nudge Distance from the Grid size/Nudge tab slider, can change the sizes of the nudges.

Once placed, the icon can be changed or edited by highlighting it and right clicking it.

Selecting Icon Options from the sub menu allows the icon to be changed to another type or resized under the Device Details tab. It can also be allocated a specific message, which will appear after the message suffix as described below. This allows specific messages to be added for individual devices in addition to the standard event messages.

After placement, the device will be shown as bold in the list indicating that it has been placed.

Repeat this procedure for all devices in all zones on all maps until all of the items in Network Navigator are shown in bold.

When the design is finished, map links should be tested to ensure that these are working correctly and the file saved.

Messages

Standard event messages

The GUIDE does not of course have to display maps or floor plans. Each event activation also has a message window, which contains the event type, node, zone, loop, address and location text as standard. Additional text can be added for each event type. This may include instructions on what to do when an event of a particular type occurs, contact telephone numbers or anything else that may be deemed suitable for the particular installation.

To access the message window click the Messages button on the top toolbar.

The left hand side of the screen allows the event type to be selected. The default header for the message is the event type but this may be changed if required. The font and colour of the message header can also be modified using the standard text formatting tools in the toolbar.

The message body is the information received from the control panel. The content of this can not be changed but the font, style and colour can be changed by selecting the Set Font button within the message body window.

The message suffix is for additional information that may be required such as instructions on emergency procedure. The font, style and colour can be changed using the standard text formatting tools in the toolbar at the top of the screen.

Specific user messages

These allow device specific additional text to be added which will appear after the message suffix. When adding a Specific user message it helps to make the message name the same as the address of the device e.g. Node 1 Loop 2, address 12.

When allocating Specific user messages (right click device icon>Icon Options>Event Message text) the message can then be searched for by its address.

3.4 Main toolbar

Arrow

The Arrow tool at the top left hand side of the main toolbar switches off the New Link/Zone button and sets the map window cursor to a cross hair (unless over a corner node).

This enables device selection, movement and editing.

New Link/Zone

Toggle button which, when on, allows new zones and links to be drawn and created on the map.

Add Nodes

Allows additional handles to be added to zone shapes for creating polygons. Additional nodes must be added between the two green nodes show on a selected zone shape.

Lock Objects

Toggle button, which prevents devices that have been placed from being moved accidentally.

New Map

Allows new map to be imported and added to the project navigator.

Messages

Allows message header text to be changed from default event type. Font can be changed.

Allows font to be changed on event text that is transmitted from the fire control panel.

Allows a message suffix to be added in any font.

Specific User messages can be set up here so that selected devices can display specific information (rather than by event type) when they are activated.

Zone Text

A text message can be added to each zone. This will be displayed at the top of the message side bar when an event is activated.

User Icons

The icons available have been designed to suit the needs of most fire systems and the standard icon for any given device type can be changed by selecting the device, right clicking it and selecting Icon Option from the menu.

This allows the default icon to be changed to any of the Standard Icons on the list or re-sized.

Icons can also be changed to user-defined icons, which have been previously created and saved.

Specific User messages can also be added by selecting the Event Message Text tab. These are messages previously created as described in **Messages**, above.

Save

Saves the currently loaded project to the specified location.

4.0 BMPGrabber

This simple utility allows CAD drawings in .dxf or .dwg format to be imported and sections of the drawing to be zoomed into (or out of) and saved in .bmp format for use within GUIDE Designer.

To use this utility, select Programs>GUIDE>BMPGrabber.

Select File>Open.DXF/.DWG Drawing, or use the file and directory list.

Locate the .dxf or .dwg file to be imported and click open.

Using the buttons at the bottom right of the image window the whole image can be zoomed into or out of using the + and – buttons or sections of the image can be zoomed into using the other tool buttons.

Select the arrow tool (zoom last) and draw around the section of the drawing to be enlarged while holding the mouse button down. This area will now appear enlarged. To restore the image press the button with the grey filled square (zoom reset).

In this way, sections of a CAD drawing (one building of a site plan for example) can be enlarged and created as a map image.

Once the desired section of the drawing has been selected, the size of the bitmap can be enlarged by clicking Edit>Set Window Size.

The background colour of the bitmap can be changed by clicking Edit>Background Colour.

The lines thickness of the drawing can be changed by clicking Edit>Thickness 1, Thickness 2 or Thickness 3.

When the image appears as required in the GUIDE designer program, select File>Save Current View As .BMP Image.

Give the file an appropriate name and save it to a location where it can be easily found later.

When the image is opened in the GUIDE Designer programme, it will appear at the same size and proportions as it did when saved in BMP grabber.

The size and proportions of the image can be modified from within the designer programme by right clicking the map and choosing Background Map Options.